



A New Dose Calibrator for Nuclear Medicine Laboratories

S. F. Marcos¹, P. F. Larissa² and R. C.
E. Nunes³

¹*msantana@ien.gov.br,*
³*revangelista@ien.gov.br, Instituto de*
Engenharia Nuclear

²*larissapfarias@ymail.com, Escola de Belas*
Artes - Universidade Federal do Rio de
Janeiro

1. Introduction

Absolute radioactivity measurement is becoming more essential in nuclear medicine for therapeutic response monitoring and individualized dosimetry. For imaging and therapy, nuclear medicine clinics employ radiopharmaceuticals with various half-lives. These radiopharmaceuticals can be administered to the patient in a variety of ways. Accurate evaluation of the quantity of activity delivered is critical for achieving reliable image quantification. Additionally, according to international recommendations, each unit dosage of radiopharmaceuticals to be delivered to a patient should be measured. Thus, in the field of nuclear medicine, dose calibrators are crucial because they're commonly used to check the activity of radioisotopes [1]. All Nuclear Medicine Services in Brazil are required to employ dose calibrators to measure the activity of solutions containing radionuclides, prior to the administration of these radiopharmaceuticals to patients for the purpose of either diagnosis or treatment of illnesses. This paper describes the development of a new dose calibrator. The equipment was developed with features similar to those found in modern dose calibrators and to fulfill the needs of nuclear medicine centers and hospitals. The equipment consists basically of an ionization chamber to measure the radio pharmaceuticals activity, an electrometer with an extremely high impedance pre-amplifier, a microcontroller unit and a tablet or microcomputer.

2. Methodology

A dose calibrator is based on a cylindrical ionization chamber filled with a pressurized gas, generally argon. The radiation released by the radiopharmaceutical to be administered interacts with the gas in the ion chamber when it is placed in the chamber. Ion pairs are formed as a result of this interaction. The negatively charged ions (electrons) travel towards the anode when a potential difference is introduced between the two electrodes in the ion chamber, generating a current signal.

A dose calibrator can be calibrated in terms of activity by comparison with an appropriate activity standard. A typical efficiency curve as a function of photon energy (Fig. 1) shows a strong peak in efficiency to thin-walled aluminum chambers at photon energies around 50 keV. A limited number of calibration coefficients are measured using standard reference sources spanning the range of energies of interest to create the curve. The chamber response caused by particular photons released by radionuclides is computed, normalized to a reference radionuclide, and plotted to produce the response-energy curve [1]. Calibration coefficients for additional radionuclides can be determined using known decay methods utilizing the resultant response-energy curve.

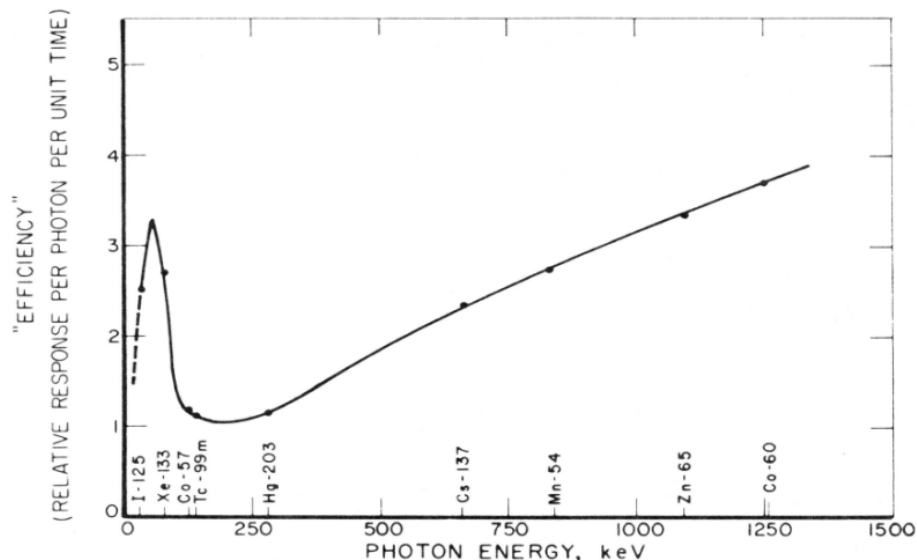

Figure 1: Efficiency curve as a function of photon energy [1].

To be useful, a dose calibrator must be capable of automatically translating the observed ionization current into an activity in becquerel (Bq) or curie (Ci) units and presenting the result to the user ($1 \text{ Ci} = 3.7 \times 10^{10} \text{ Bq}$). The dose calibrator lacks energy selectivity; the measured charge represents the total ionizations generated by interactions of all photons emitted by a certain isotope [2].

Administration of precise dose of radiopharmaceutical not only ensures permissible radiation dose to patient but also is mandatory for optimization of the scan exams [3]. At that, precise and accurate functioning of dose calibrator in nuclear medicine pharmacy is mandatory. Quality tests for dose calibrators should include measurements of the accuracy, reproducibility, linearity and geometry response. The accuracy is determined by comparing activity measurements using a traceable calibrated standard with the supplier's stated activity, corrected for radioactive decay. The reproducibility, or constancy, can be assessed by taking repeated measurements of the same source. If the sample holder is removed from the chamber between each measurement, the measured reproducibility will include any errors associated with possible variations in source position [1]. Linearity test is designed to prove that the dose calibrator readout is linear for sources varying from the μCi range through the mCi range. Geometry test is designed to show that correct readings can be obtained regardless of the sample size or geometry, for example, positioning of glass vial and syringe appropriately.

Another important characteristic for dose calibrator is the background subtraction. When the source holder is empty, the dose calibrator will still record a non-zero reading due to background radiation. This will comprise natural background and background from sources within the radiopharmacy. Non-zero reading may be also partially due the electronic circuits, mainly the electrometer. Fig. 2 shows the main parts of the new equipment under development. These parts are described below.

- A - Source Holder - the sample holder places the radioactive source in the location which is at the proper measurement geometry within the detector.
- B - Detector Well liner - It's a plastic liner to protect the detector from contamination.
- C - The Detector - It's a cylindrical well ionization chamber, constructed of aluminium filled with argon under pressure.
- D - Electrometer, high voltage power supply and microcontroller unit.
- E - Shield with 6 mm of lead to ensure low background readings.

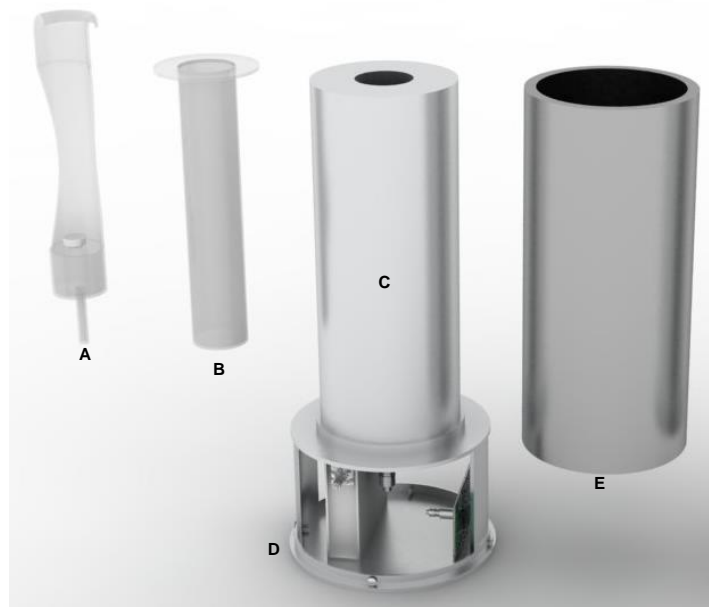

Figure 2: Main part of the dose calibrator.

3. Results and Discussion

The development of a digitally controlled electrometer with ultra-low current sensitivity is the main work of this project. The instrument can measure a current of less than one picoampere. In the picoampere world, there are three common enemies: current leakages, noise sources, and stray capacitance. A good low-current design must minimize the effects of these common enemies and strike a balance between optimal performance and product manufacturability. The amplifier's inverting input node and its feedback elements are critical nodes. The current leakage in this node determines the ultimate accuracy of the device. The electrometer developed is characterized by low-noise, fast-response, high-sensitivity and compactness. The electrometer has the amplifier sensitivity controlled by the MSP430 device, an ultra-low power microcontroller with an integrated 16 bits A/D converter. The tested circuit topologies obtained good results.

The graphical user interface developed uses the human centered design approach, under guidance from LABUCH (Laboratório de Usabilidade e Confiabilidade Humana) from IEN. The human centered design emphasizes the use of ergonomics methods to collect human performance data, so that the allocation of users' needs in all phases of equipment design can be guaranteed [4]. The main screen of the dose calibrator is shown in Fig. 3. The unit chosen for control functions and display measurements was an Ipad tablet. Easy to read and intuitive to use, the touch screen display prompts users to advance effortlessly and logically through the dose calibrator. On the main screen the system operates as a dose calibrator. The measured activity is the real time activity being measured in the detector for the isotope selected. As an extra option, the same screen could run on a microcomputer with a touch screen. In addition to measuring isotopes activity, the dose calibrator screen allows the user to Zero Background, select an isotope, perform dose calculation, or print labels for the current activity in the detector. The user can select wireless printers to print labels.

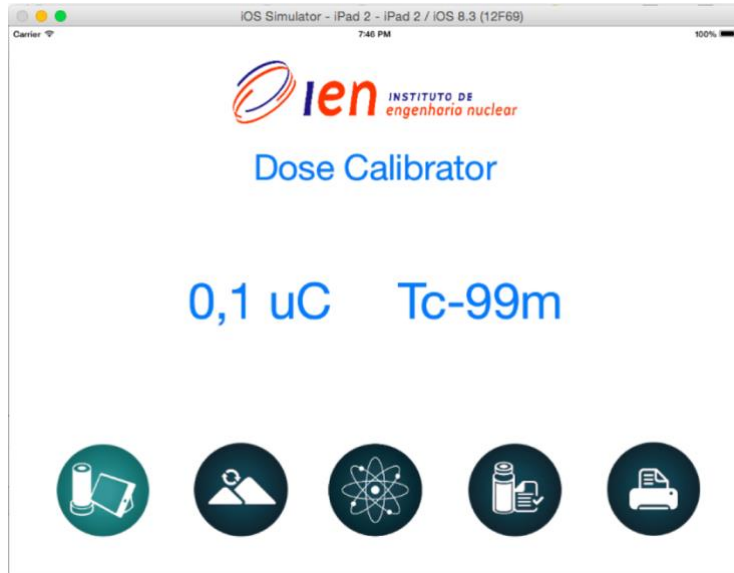

Figure 3: Main screen of the dose calibrator display unit.

4. Conclusions

In this paper the authors have presented the design of the new dose calibrator developed at IEN. The equipment simplifies the production and modernizes the user interface by using a tablet or touch screen monitor as a control and display unit. New functions can be easily programmed and aggregated to the equipment using these devices. An electrometer easy to produce and with high sensitivity is also an important advantage in this project. The equipment has operational qualities that are similar to a model previously developed by the IEN, the dose calibrator 13002, according to tests for accuracy, repeatability, linearity, and geometric response. The equipment will be subjected to specific tests to further characterize the detector and allow a more efficient calibration. It should be emphasized that this equipment is part of a set of instruments produced in Brazil that satisfy the requirements of the regulatory standard for nuclear medicine centers on basic radiation protection equipment.

Acknowledgements

The authors gratefully acknowledge the infrastructure and financial support of Instituto de Engenharia Nuclear.

References

- [1] D. Bailey, J. Humm, A. Todd-Pokropek, and A. van Aswegen. Nuclear Medicine Physics: a handbook for teachers and students. International Atomic Energy Agency, 2014.
- [2] A. F. Jacobson, R. Centofanti, O. I. Babalola, and B. Dean. Survey of the performance of commercial dose calibrators for measurement of ^{123}I activity. *Journal of Nuclear Medicine Technology*, 39(4), 2011.
- [3] K. Khan, G. Khan, S. Saleem, N. Hameed, M. Naqvi, and M. uz Zaman. Accuracy and constancy tests of dose calibrator at akuh, karachi: A clinical audit: safety is quality. *Pakistan Journal of Radiology*, 2013.
- [4] I. J. L. A. Santos, M. S. Farias, B. G. Monteiro, M. Falco, and F. D. Marcelino. Using participatory ergonomics to improve nuclear equipment design. *Journal of Loss Prevention in the Process Industries*, 24:594–600, 2011.