



Growth of Scintillating Bromide-doped Cesium Iodide Crystals for Radiation Detection

J. P. S. Alves¹, T. M. Filho, M. C. C. Pereira

¹ jpsalves@usp.br

1. Introduction

Scintillators (i. e. materials that emit light upon interaction with high-energy radiation) have been in use for a long time, specially after the development of electronic devices capable of amplifying and counting the light produced by them, and new alternatives are still in high demand[1]. One such material are cesium iodine crystals. Pure CsI crystals are poorly hygroscopic, easy to handle and, most importantly, have a short decay time of ~ 10 ns[2]. However, they have a low light yield, which led to the development of two of its most well known alternatives: Na- and Tl-doped CsI crystals, both of which have a higher light yield than their pure counterpart (~ 65000 ph/MeV for CsI(Tl), for example), at the cost of higher decay times (~ 1300 ns, again for CsI:Tl), limiting their use in applications such as counters. A way to try and remedy this situation is through the doping of CsI crystals with bromide ions. CsI:Br crystals show interesting characteristics. Even though their light yield is lower than that of CsI:Tl and CsI:Na, it's higher than that of pure CsI. Also, and perhaps most importantly, it's decay times are much shorter than those of the other two, reaching levels comparable to those of pure CsI depending on the doping element's concentration[3], as well as having good levels of transmittance and being responsive to alpha, gamma and neutron radiations[4]. More generally, in regards to other scintillators, bromine-doping has recently been shown to enhance the characteristics, notably the light yield and time resolution, of methylammonium lead halide crystals, specially when working at low temperatures[5]. All of this makes the CsI:Br crystal a good candidate for radiation detection when both a sizeable light yield and fast responses are needed. Thus, the goal here is to show a method of growing CsI:Br crystals using the Bridgman technique for use as radiation detectors.

2. Methodology

The Bridgman technique consists of descending the molten salts mixture (in this work, CsI and CsBr) through a temperature gradient in such a way that the solidification creates a single crystalline cell; the crystallization of the whole material will then follow the orientation of this first cell. To achieve this, a 400 mm x 26,25 mm quartz crucible was used. The crucible has a conical tip, so that its small volume may induce the creation of the single primordial cell. Fig.1 shows the geometric configuration of the crucible.

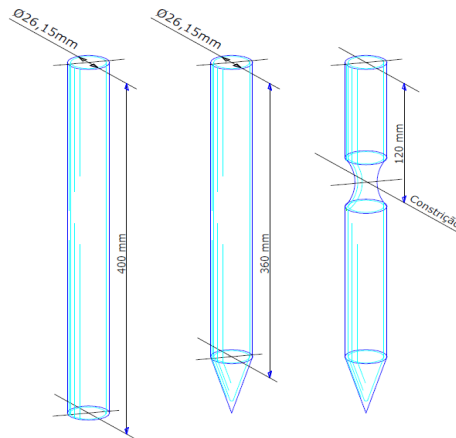

Figure 1: Diagram of the quartz crucible.

Before its use, the crucible is washed with neutral detergent 10% for 24 hours, then with HF 5% for 30 minutes, then thoroughly washed with ultrapure water, after which it's left to dry in an oven for 24 hours and, subsequently, connected to a vacuum pump and put under a temperature of 500°C for 5 hours to remove residual humidity from its walls. The source salts are then weighted: 100g of a mixture of CsI (the matrix) and CsBr (the dopant) at a ratio of $\text{CsBr/CsI} = 10^{-2}$. The salts are then introduced into the crucible which is again connected to the vacuum pump for the treatment of the salts at 350°C for 8 hours, after which the crucible is taken to a sealed box with argon atmosphere. There, 0.5% of solid iodine is added to the crucible to fill in eventual gaps in the crystalline structure during its solidification. The crucible is connected once more to the vacuum pump for about 20 minutes to remove all the argon and ensure that there are no more gases in the crucible that may create bubbles and other imperfections in the crystal. The crucible is then sealed via a constriction on its neck and taken to the Bridgman oven at 680°C. The part containing the salts is lined with the hottest zone of the oven and, when the whole material is molten, it's left in the oven for 96 hours, with a descending rate of 1 mm/h. When this is over and the crystal has cooled down, it's taken to another tube and goes to a regular oven for 4 hours at 350°C to remove all the excess iodine still left in the crystal.

To study the response to gamma radiation and alpha particles, the crystals were machined, polished and directly coupled to the bi-alkaline photomultiplier tube. A 2 cm diameter and 5 mm thick crystal was used.

3. Results and Discussion

When out of the Bridgman oven, the crystal exhibits a clean surface with dark brown color due to the excess of iodine still present in it. After the second heat treatment for the removal of said iodine, the crystal becomes much clearer, nearly transparent. Fig. 2 shows both situations (left and center, respectively). With the help of incident light, one can see that its interior is free of imperfections (Fig. 2 right). Even though there's some roughness to the surface of the crystal, these are of no importance for its use and can be removed via polishing.



Figure 2: CsI:Br as it left the Bridgman oven (left), and the same crystal after the second heat treatment with its tip cut off (center and right).

Fig. 3 shows alpha spectroscopy results for ^{241}Am radiation (5.54 MeV) obtained with the CsI:Br crystal.

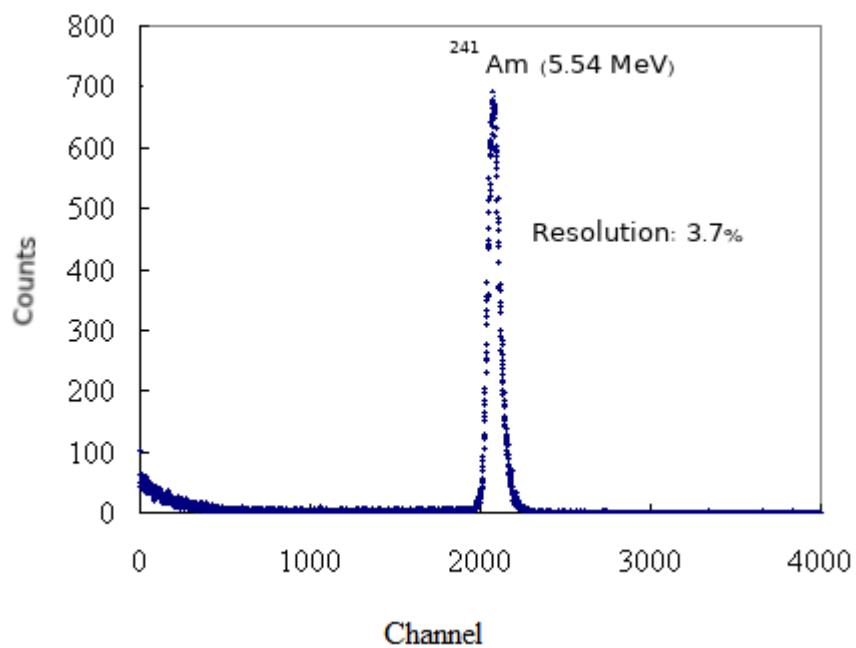

Figure 3: Spectrum obtained for the radiation of ^{241}Am using the CsI:Br 10^{-2} M crystal.

4. Conclusions

The Bridgman technique proved to be adequate for the growth of bromine-doped CsI crystals for the use as radiation detectors. The crystal produced in this manner for the purpose of this work shows good visual qualities, such as lack of anomalies in its interior and no opaque zones, and is ready to be cut into the desired dimensions and put to use. The CsI:Br crystal obtained showed a response to alpha particle radiation with a defined peak spectrum and resolution of 3.7%.

References

- [1] C. Dujardin, E. Auffray, E. Bourret-Courchesne, P. Dorenbos, P. Lecoq, M. Nikl, A.N. Vasil'ev, A. Yoshikawa, R.-Y. Zhu, "Needs, trends and advances in inorganic scintillators", *IEEE Transactions on Nuclear Science*, vol. 65, n. 8, pp. 1977-2019 (2018).
- [2] S. Kubota, S. Sakuragi, S. Hashimoto, J. Ruan, "A new scintillator material: pure CsI with 10 ns decay time", *Nuclear Instruments and Methods in Physics Research A*, vol. 268, pp. 275-277 (1988).
- [3] M. C. C. Pereira, M. M. Hamada, "Luminescence and scintillation characteristics in the CsI:Br crystal on Br concentrations", *Nuclear Instruments and Methods in Physics Research A*, vol. 537, pp. 189–192 (2005).
- [4] L. Swiderski, M. Moszynski, A. Nassalski, A. S. Kazuch, W. Czarnacki, W. Klamra, V. A. Kozlov, "Scintillation properties of undoped CsI and CsI doped with CsBr", *IEEE Transactions on Nuclear Science*, vol. 55, n. 3, pp. 1241-1245 (2008).
- [5] J. Liu, D. Hei, Q. Xu, X. Tan, J. Ruan, X. Ouyang, J. Nie, K. Wei, Q. Xu, B. Sun, "Low temperature scintillation performance of a Br-doped $\text{CH}_3\text{NH}_3\text{PbCl}_3$ single-crystalline perovskite", *RSC Advances*, vol. 11, pp. 2020 – 2024 (2021).